

33 The Atoms of Environmental Structure

Christopher Alexander and Barry Poyner

Center for Environmental Structure
2701 Shasta Road
Berkeley, California, and
Department of Architecture
University of Aston
Birmingham, England

Christopher Alexander is Associate Professor of Architecture at the University of California and Director of the Center for Environmental Structure in Berkeley. He was born in Austria and educated in England. He received an M.A. in mathematics in 1956 and a B.A. in architecture in 1958 from Cambridge University and a Ph.D. in architecture from Harvard in 1963. He has lectured, consulted, and published extensively in several fields. His major work is *Notes on the Synthesis of Form*. Barry Poyner is on the research staff of Scientific Control Systems Ltd. in London and is a Research Fellow at the University of Aston. He was born and educated in England, receiving the Dip. Arch. in 1960 from the Birmingham School of Architecture. He has been associated with the Directorate of Works of the British War Office and the Development Group of the Ministry of Public Buildings and Works in London. The present work was done in association with John Redpath and Ian Moore of the Offices Development Group, Ministry of Public Buildings and Works, London, in 1966–1967. The first part of the paper was printed under the same title by the Center for Planning and Development Research of the University of California and subsequently by the Ministry.

This paper is about design programming. The atoms of environmental structure are relations, the simplest geometry which can be functionally right or wrong in the design of any man-made object or environment. They are statements about the physical organization which is required if the design is to function well. A list of required relations replaces the design program or brief and the first stages of sketch design. The argument of the paper has four parts. First, the idea of need should be replaced with its operational counterpart, tendency. Second, a single need, when operationally defined, makes no demands on the physical environment, and the environment requires a specific geometry only to resolve conflicts between tendencies. Third, once a conflict between tendencies is clearly stated, it is possible to define the geometrical relation required to prevent the conflict and to insist that this relation be present in any context where the conflict might occur. Finally, the environment needs no geometrical organization beyond that which it gets from combinations or relations so defined. Two appendices follow, the first illustrating specific tendencies, conflicts, and relations for the entrance to an office and the second illustrating tendencies, conflicts, and patterns for the entrance to a suburban house.

At present, there are two things wrong with design programs. First of all, even if you state clearly what a building has to do, there is still no way of finding out what the building must be like to do it. The geometry of the building is still a matter for the designer's intuition; the program does not help. Second, even if you state clearly what the building has to do, there is no way of finding if this is what the building ought to do. It is possible to make up an arbitrary program for a building. There is, at present, no way of being sure that programs are not arbitrary; there is no way of testing what the program says.

As far as this second point goes, most designers would maintain that no program can ever be made nonarbitrary. They would say that the rightness or wrongness of a program is not a factual matter but a moral one; it is not a question of fact but a question of value. These people argue in the same way about the physical environment itself. They say that the environment cannot be right or wrong in any objective sense but that it can only be judged according to criteria, or goals, or policies, or values, which have themselves been arbitrarily chosen.

We believe this point of view is mistaken. We believe that it is possible to define design in such a way that the rightness or wrongness of a building is

clearly a question of fact, not a question of value. We also believe that if design is defined in this way, a statement of what a building ought to do can yield physical conclusions about the geometry of the building directly. We believe, in other words, that it is possible to write a program which is both objectively correct and which yields the actual physical geometry of a building.

What Is a Need?

Let us begin with the kind of programs which people write today. It is widely recognized that any serious attempt to make the environment work must begin with a statement of user needs. Christopher Jones calls them performance specifications; Bruce Archer calls them design goals; in engineering they are often called design criteria; at the Building Research Station they are called user requirements; at the Ministry of Public Building and Works they have been called activities; they are often simply called requirements or needs. Whatever word is used, the main idea is always this: Before starting to design a building, the designer must define its purpose in detail. This detailed definition of purpose, goals, requirements, or needs can then be used as a checklist. A proposed design can be evaluated by checking it against the checklist.

But how do we decide that something really is a need? The simplest answer, obviously, is "Ask the client." But people are notoriously unable to assess their own needs. Suppose then, that we try to assess people's needs by watching them. We still cannot be sure we know what people really need. We cannot decide what is "really" needed, either by asking questions, or by outside observation, because the concept of need is not well defined. The word need has a variety of meanings. When it is said that people need air to breathe, it means that they will die within a few minutes if they do not get it. When someone says, "I need a drink," it means he thinks he will feel better after he has had one. When it is said that people "need" an art museum the meaning is almost wholly obscure. The statement that a person needs something has no well-defined meaning. We cannot decide whether such a statement is true or false.

We shall, therefore, replace the idea of need by the idea of what people are trying to do. We shall, in effect, accept something as a need if we can show that the people concerned, when given the opportunity, actively try to satisfy the need. This implies that every need, if valid, is an active force. We call this active force which underlies the need a tendency. A tendency, therefore, is an operational version of a need. If someone says that a certain need exists, we cannot test the statement, because we do not know what it really claims. If someone says that a certain tendency exists, we can begin to test the statement.

Here is an example. Suppose we say, "People working in an office need a view." This is a statement of need. It can be interpreted in many ways. Does it mean "It would be nice if people in offices had views"? Does it mean "People say they want a view from their offices"? Does it mean "People will pay money to get a view from their offices"? There are so many ways of interpreting it that the statement is almost useless. We do not know what it really says.

But if we replace it by the statement, "People working in offices try to get a view from their offices," this is a statement of fact. It may be false, it may be true, but it can be tested. It is a statement of a tendency. If observation shows that people in an office actively try to get those desks which command a view, it is clearly reasonable to say that they need the view. If, on the other hand, people make no effort to get a view even when they get the chance, we shall naturally begin to doubt the need.

Every statement of a tendency is a hypothesis, an attempt to condense a large number of observations by means of a general statement. In this sense, a statement of a tendency is like any scientific theory. Since a statement of a tendency is a way of interpreting observations, we must try as hard as pos-

sible to rule out alternative hypotheses. Suppose we have observed that people in offices try to get desks near the window when they get the chance. It is possible to infer from this that they are trying to get a view. But we might equally well infer the existence of other tendencies. They could be trying to get more light, or better ventilation, or direct sunlight. Or they may be trying to get something far more complicated; they may want to be in a position from which they see the light on the faces of their companions instead of seeing them in silhouette against the window.

In order to be confident that people really seek a view, we must make observations which allow us to rule out such alternative interpretations one by one. For example, suppose we construct an office in which light levels are uniform throughout, because windows are supplemented by artificial light. Do people still try to work near the window in such an office? If they do, we can rule out the possibility that they are merely trying to get more light. Ruling out all the alternative interpretations we can think of is a laborious and expensive task. Furthermore, in order to make the hypothesis more accurate, we must try to specify what kind of people seek a view from their offices, during what parts of their work they seek it most, what aspects of "view" they are really looking for, and so on. Again, this is a laborious and expensive task. It is like the task of forming any scientific hypothesis or theory. A good theory cannot be invented overnight; it can be created only by refinement over many years and by many independent, different observers.

It is, therefore, vitally important that we do not exaggerate the pseudo-scientific aspect of the concept of tendency. Since a tendency is a hypothesis, no tendency can be stated in any absolute or final form. The ideal of perfect objectivity is an illusion, and therefore there is no justification for accepting only those tendencies whose existence has been "objectively demonstrated." Other tendencies, though they may be speculative, are often more significant from the human point of view. It would be extremely dangerous to ignore such tendencies just because we have no data to "support" them. Provided they are stated clearly, so that they can be shown wrong by someone willing to undertake the necessary experiments, it is as important to include these tendencies in the program as it is to include those tendencies that we are sure about.

Conflicts

Now we face the central problem of design: Given a statement of what people need, how can we find a physical environment which meets those needs?

In order to answer this question we must first define clearly just what we mean by meeting needs. This is not as easy as it seems. So long as we are using the word needs, the idea of meeting them seems fairly obvious. However, once we replace the idea of need by the idea of tendency and try to translate the idea of meeting needs into the new language, we shall see that its meaning is not really clear at all.

The idea of needs is passive. But the idea of tendencies is highly active. It emphasizes the fact that, given the opportunity, people will try to satisfy needs for themselves. When we try to interpret the idea of meeting needs in the light of this new emphasis, we see that it is highly ambiguous. To what extent are people expected to meet needs for themselves, and to what extent is the environment expected to do it for them?

Take for example a simple situation, a man sitting in a chair. He has various needs. He needs to shift his position every now and then, to maintain the circulation in his buttocks and thighs. If he is trying to read, he needs enough light to read by. If he sits in his chair long enough, he will need food or refreshment. He needs ventilation. Under normal circumstances he is perfectly able to meet these needs for himself. But if we define a good environment as one which meets needs, we should logically be forced to design an environment which meets these needs for him. This conjures up an image of

a man lying in an armchair, food being fed him mechanically, a window opening automatically when the room becomes too hot, a light being switched on automatically as evening comes, and pads in the chair massaging his buttocks to keep the pressure from building up too much in any one place.

The image is absurd. It is absurd because the man is perfectly capable of meeting these needs for himself. Indeed, not only is he capable of meeting them for himself, but for his own well-being it is almost certain that he should meet them for himself. Man is an adapting organism. A man who is no longer meeting his needs is no longer adapting. The daily, hourly, process of adapting is the process of life itself; an organism which is no longer adapting is no longer alive.

It is, therefore, clear that a good environment is not so much one that meets needs as one that allows men to meet needs for themselves. If we define a need as a tendency, as something which people are trying to do, then we must assume that they will do it whenever they get the chance. The only job which the environment has is to make sure they get this chance.

Now at first sight it may seem that the argument leads to a dead end. Go back to the example of the man sitting in a chair. Under normal conditions each one of the tendencies which arises in this situation can take care of itself. The man can do everything for himself. There is no problem in the situation. The environment does not require redesign. If needs are defined as tendencies, and if tendencies are capable of taking care of themselves, then why does the environment ever require design by designers? Why cannot people be left to adapt to the environment and to shape their own environment as they wish, with the help of bricklayers, carpenters, electricians, and others. If tendencies are active forces, then people will presumably take action whenever the environment is not satisfactory and will meet their own needs for themselves. Why does the environment need design? Why should designers ever take a hand at all?

The answer is this. Under certain conditions, tendencies conflict. In a *conflict* situation, the tendencies cannot take care of themselves, because one is pulling in one direction, and the other is pulling in the opposite direction. Under these circumstances, the environment does need design; it must be rearranged in such a way that the tendencies no longer conflict.

Let us go back once more to the man sitting in a chair. There are certain chairs, made of canvas slung between wire supports, in which you cannot move about at will, because your body always sinks to the lowest position and is held there by the canvas. After sitting in one of these chairs for a few minutes you begin to feel uncomfortable; the pressure on certain parts of the body builds up, but you cannot move slightly to reduce this pressure. You try to shift positions but you cannot. At first sight it might seem that this is not so. Indeed, the tendency to try to reduce the pressure on your body has a simple outlet. You can simply get up and walk about. The trouble is, of course, that in many cases there will be another tendency operating which makes you want to stay sitting where you are. It is the conflict between your tendency to stay where you are and your tendency to shift position which makes a problem. In a properly designed chair this conflict does not occur.

We may, therefore, replace the simple-minded definition of a good environment as one that meets needs, by the following definition: a good environment is one in which no two tendencies conflict.

Of course, the conflicts that occur in buildings and cities can be much more complicated than the one we have just described. There can be conflicts between tendencies within a single person, between one person and a tendency of a group, or between a tendency in a person and some larger tendency that is part of a mass phenomenon. But the principle is always the

same. Provided that all the tendencies can operate freely and are not brought into conflict with other tendencies, the environment in which they are occurring is a good one. It follows then that the environment only requires design in order to prevent conflicts occurring. If we wish to specify the pattern an environment ought to have, we must begin by identifying all conflicts between tendencies which might possibly occur in the environment.

In summary: Until we have managed to see design problems in terms of conflict between tendencies, there is nothing for the designer to do. So long as we see nothing but isolated tendencies we must assume that they will take care of themselves. We have only succeeded in stating a design problem in a constructive way at that moment when we have stated it as a conflict of tendencies. Since the tendencies in conflict may often be hidden, to state the problem is a difficult process which requires a deliberate and inventive search for conflicts.

Relations



patterns

We design the environment, then, to prevent conflict. We must now start talking about the features of buildings which can help us do this. The features that cause and prevent individual conflicts are not bricks, or doors, or roofs; they are geometrical relationships between such concrete pieces. We shall call them *relations*.

Before describing how we invent a new one, let us look at some examples of well-known relations. Here are five typical relations from a supermarket:

1. Check-out counters are *near* the exit doors.
2. The stack of baskets and trolleys is *inside* the entrance and directly *in front* of it.
3. Meat and dairy refrigerators are *at the back* of the store, and all other goods on display are *between* these refrigerators and the check-out counters.
4. Display shelving has a *tapering* cross section, narrow at the top and wider at the bottom.
5. The store is glass-fronted, with aisles running from *front to back at right angles* to the street.

These relations have become widely copied and typical of supermarkets because each of them prevents some specific conflict. Here are the five relations, followed in each case by the conflicts.

Check-out near exit doors. This relation prevents a conflict between the following tendencies:

1. Management has to keep all goods on the sales side of the check-outs.
2. Management is trying to use every square foot of selling space.

Baskets or trolleys inside the entrance and directly in front of it.

1. Management tries to encourage shoppers to use baskets, so that they are not reluctant to pick up extra goods.
2. Shoppers tend to move as fast as possible for the goods and are therefore likely to miss the baskets.

Meat and dairy products at the back of the store and all other goods between these counters and the check-outs.

1. Management tries to get every shopper to walk past as many goods as possible.
2. Shoppers visit meat and dairy sections almost every time they go to the supermarket.

Display shelving with tapering cross section so goods near the ground are clearly visible to shoppers.

1. People tend to walk around a supermarket without bending down constantly to look for goods.
2. People want to be able to find the goods they are looking for without having to ask.

Glass fronts, aisles running back from the street and at right angles to it.

1. Management is trying to give passersby a view of the entire inside of the supermarket, to draw them in.
2. If the supermarket is on a street most of the passersby are walking past the front.

A relation, then, is a geometrical arrangement that prevents a conflict. No relation can be regarded as necessary to a building unless it prevents a conflict that will otherwise occur in that building. A well-designed building is one which contains enough relations to eliminate conflicts within.

So far we have discussed only known relations, those which exist already. How do we invent a new relation? Obviously, we start by stating a conflict. But how do we invent a relation that prevents the conflict? The key is this: tendencies are never inherently in conflict; they are brought into conflict only by the conditions under which they occur. In order to solve the conflict we must invent an arrangement where these conditions do not exist. For example, where a public path turns the corner of a building, people often collide. The following tendencies conflict: (1) People are trying to see anyone approaching them some distance ahead, so that they can avoid bumping into them without slowing down, and (2) going round a corner, people try to take the shortest path. At the blind corner the first tendency makes people walk well clear of the corner, the second makes them hug the corner. At a blind corner the tendencies conflict.

Before we can invent an arrangement that prevents this conflict, we must find out exactly what makes these tendencies conflict. In our example there are several aspects of blind corners to blame: the fact that the corner is solid, the corner is square, and the ground is unobstructed around the corner. To eliminate the conflict we must get rid of one or more of these features. If we make the corner transparent, people will be able to see far enough ahead through it. If we round the corner with a gradual curve, people will be able to see round the corner. If we place a low obstruction at the corner, like a flower tub, people will have to walk around it and will see each other over it.

It is plain from the example that there are certain arrangements causing the conflict and certain "opposite" arrangements preventing the conflict. These two classes of arrangement are mutually exclusive. Our task, given any conflict, is to define the class of arrangements that prevents the conflict. This is always difficult. In theory the class is infinite; even in practice it is very large. We must, therefore, define an abstract geometric property shared by all arrangements in the class and by no others. This is what we mean by a relation. A relation is a precise geometric definition of the class of arrangements preventing a given conflict. It must be so worded as to include all the arrangements that prevent the conflict and exclude all those which cause it.

Let us continue our example. We have described certain arrangements that cause a conflict at corners and others that prevent it. Those preventing it include: a corner made of transparent materials, a rounded corner, a tub of flowers so placed that people have to walk clear of the corner. What is the property common to all these good arrangements, which the bad arrangements lack? Roughly speaking, it is this: If we define a path around the corner at a distance of one foot out from all walls and objects which project from the ground, and if we examine all chords on this path which are less than fifteen feet long, we shall find that none of these chords is, at eye level, obstructed by anything opaque.

The conflict in this example happens to be a simple one. However, even when the conflicting tendencies are much larger in scale, or more subtle, the logic is the same. We state the conflict, give examples of arrangements causing, and preventing it, and then try to abstract the relation that defines the latter class.

Two minor points remain. First, conflicting tendencies occur under specific conditions. The relation required to prevent the conflict is required only under these specific conditions. The conditions under which the conflicting tendencies occur must be stated as part of the relation. Thus, the final form of a relation will always be: "If such and such conditions hold, then the following relation is required." Second, the actual process of inventing a relation will not follow the process of finding conflicts and defining relations in strict sequence, as it has been presented here. In practice, the statement of tendencies, the statement of conflict, and the statement of relation all develop together.

Let us summarize what we have done. We have described a process which has two steps: (1) identifying a conflict, and (2) deriving a relation from it. This process for obtaining a relation is objective in the sense that each of its steps is based on a hypothesis that can be tested. The two hypotheses are: (1) under certain specific conditions such and such conflicting tendencies occur, and (2) under these conditions the relation is both necessary and sufficient to prevent the conflict. If we cannot show that either of these hypotheses is false, we must then assume that any building where the conflict can occur must contain the relation specified.

In order to create a building in which no tendencies conflict, the designer must try to predict all the conflicts that could possibly occur in it, define the geometric relations that prevent these conflicts, and combine these relations to form a cohesive whole.

The Scientific Attitude to Relations

The point of view we have presented is impartial. This is its beauty. Because it is impartial, it makes possible a sane, constructive, and evolutionary attitude to design. It creates the opportunity for cumulative improvement of design ideas. Everything hinges on one simple question: What does a designer do when faced with a relation which someone else has written?

The traditional point of view about design says that the rightness and wrongness of a relation is a question of value. A designer with this point of view will claim that a relation can be judged only by subjectively chosen criteria or values. Since people value things differently we can never be certain that one designer will accept another designer's opinion and there is, therefore, no basis for universal agreement.

Our point of view is different. We believe that all values can be replaced by one basic value: Everything desirable in life can be described in terms of freedom of people's underlying tendencies. Anything undesirable in life—whether social, economic, or psychological—can always be described as an unresolved conflict between underlying tendencies. Life can fulfill itself only when people's tendencies are running free. The environment should give free rein to all tendencies; conflicts between people's tendencies must be eliminated. In terms of this view, the rightness or wrongness of a relation is a question of fact.

As we have said, each relation is based on two hypotheses: (1) the conflicting tendencies do occur as stated, under the condition specified, and (2) the relation proposed is both necessary and sufficient to prevent conflict between these tendencies. Faced with a relation stated in this form, the designer must either accept it or show that there is a flaw in one of the hypotheses. Whatever he does, he cannot merely reject the relation because he does not like it. The body of known relations must, therefore, grow and improve. Design, if understood as the invention and development of relations, is no longer merely a collection of isolated and disconnected efforts. It becomes a cumulative scientific effort.*

* Since the first version of this paper was written, the theoretical framework has been developing. For example, the term "relation" has been supplanted by the term "pattern," as the latter gives a more accurate picture of the fact that the entities are spatial and are conditional on context. Several workers in Berkeley have been developing the idea of a pattern language as a system that gives the grammar of the combinatory process. See Francis Duffy and John Torrey, "A Progress Report on the Pattern Language," in this volume.

Appendix A
Relations for an Office Entrance

The relations presented in the original study¹ prescribed the organization of an office entrance situated on a busy city street. It was assumed that the building was built right up to the sidewalk, so that the entrance opened directly onto the street. It was also assumed that there was a receptionist in the entrance. The relations dealt with the arrangement of pavement, entrance doors, elevators, reception desk, and seats for visitors. In each case, the statement of the relation was accompanied by a written explanation and a diagram to show how the relation was incorporated into the whole entrance structure shown in Figure 5.

For the purpose of this extract, four examples from the original twenty-two relations have been chosen. Relations 1, 2, and 3 have been chosen because they illustrate the way in which relations can be combined. Relations 2 and 3 interlock neatly with the general structure defined by Relation 1. The overlapping and interweaving of relations is characteristic of relational design, and it makes possible the creation of compact and economic forms. Relation 4 is included because it illustrates particularly clearly the idea of conflict.

The parts of the building on the ground floor, adjacent to the entrance, must be set back to allow the entrance to project.

The following tendencies conflict:

1. Some people coming to the building will be unfamiliar with its location. They will know roughly where it is and on which side of the street, but because the street is busy, they will tend to cross to the correct side at an intersection well before reaching the building. But the building is built right up to the sidewalk, so they will approach it at an acute angle and may have difficulty seeing the entrance.
2. On a busy sidewalk people try to work out their route some distance ahead, to preposition themselves to take the shortest path.²

Some arrangements which cause this conflict are as follows: If the entrance doors are recessed and there is no projection at the entrance, people will tend to move to the outside edge of the sidewalk to see along the building more clearly. If they do this, they cannot preposition themselves to take the shortest path into the entrance because they will have to bob and weave their way across the path of other pedestrians. A projecting canopy will not necessarily be associated with the entrance. If there is a low projection, like a step, people will not see it because it will be obscured by other pedestrians.

Arrangements which may prevent the conflict are these: Some projections, for example, a classical portico with columns, a projecting lobby, or a revolving door, can be seen by people approaching the entrance at an acute angle. Such projections are roughly single-story height. In the example in Figure 1, the building is built right up to the sidewalk, so the entrance cannot project onto it. To gain a projection, the parts of the ground floor on either side of the entrance must be set back.

A covered linear recessed space, at the side of the entrance doors, about two feet deep and roughly parallel to the street.

Where the building entrance opens directly onto the sidewalk, the following tendencies conflict:

1. When it begins to rain heavily, people in the street take shelter in the entrance for awhile. They try to stand out of the way of others going in and out.
2. While sheltering in an entrance, people tend to stand in a line facing the street. It is characteristic of human behavior that people in crowds avoid standing face to face.

1. This study was conducted by Barry Poyner in 1966. The complete study is available from the Ministry of Public Buildings and Works, London.

2. See Tyrus Porter, "A Study of Path-Choosing Behavior," in particular the study of the Kaiser Center lobby.

Relation 1.

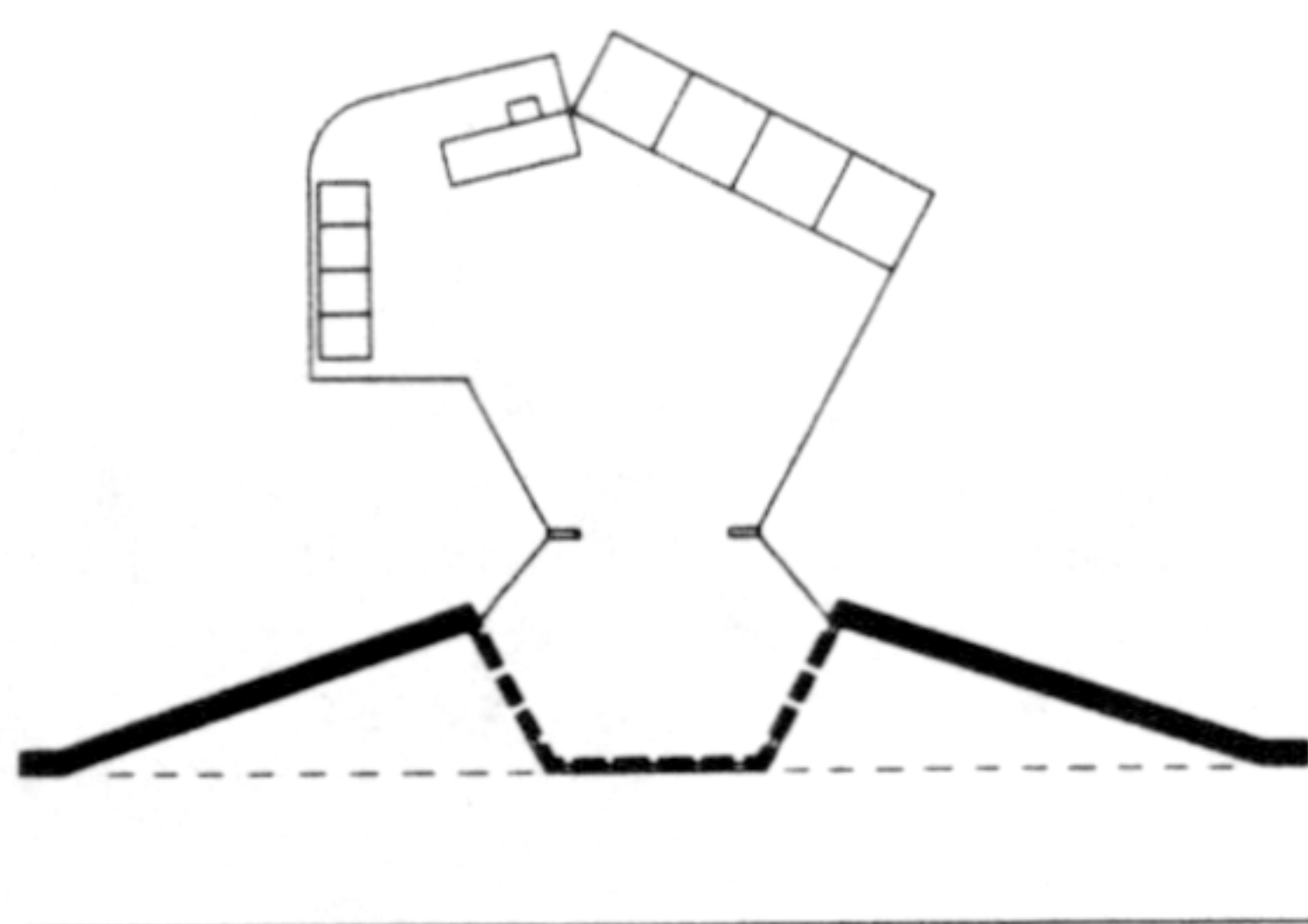

1. Diagram of the relation for projection of entrance

Relation 2.

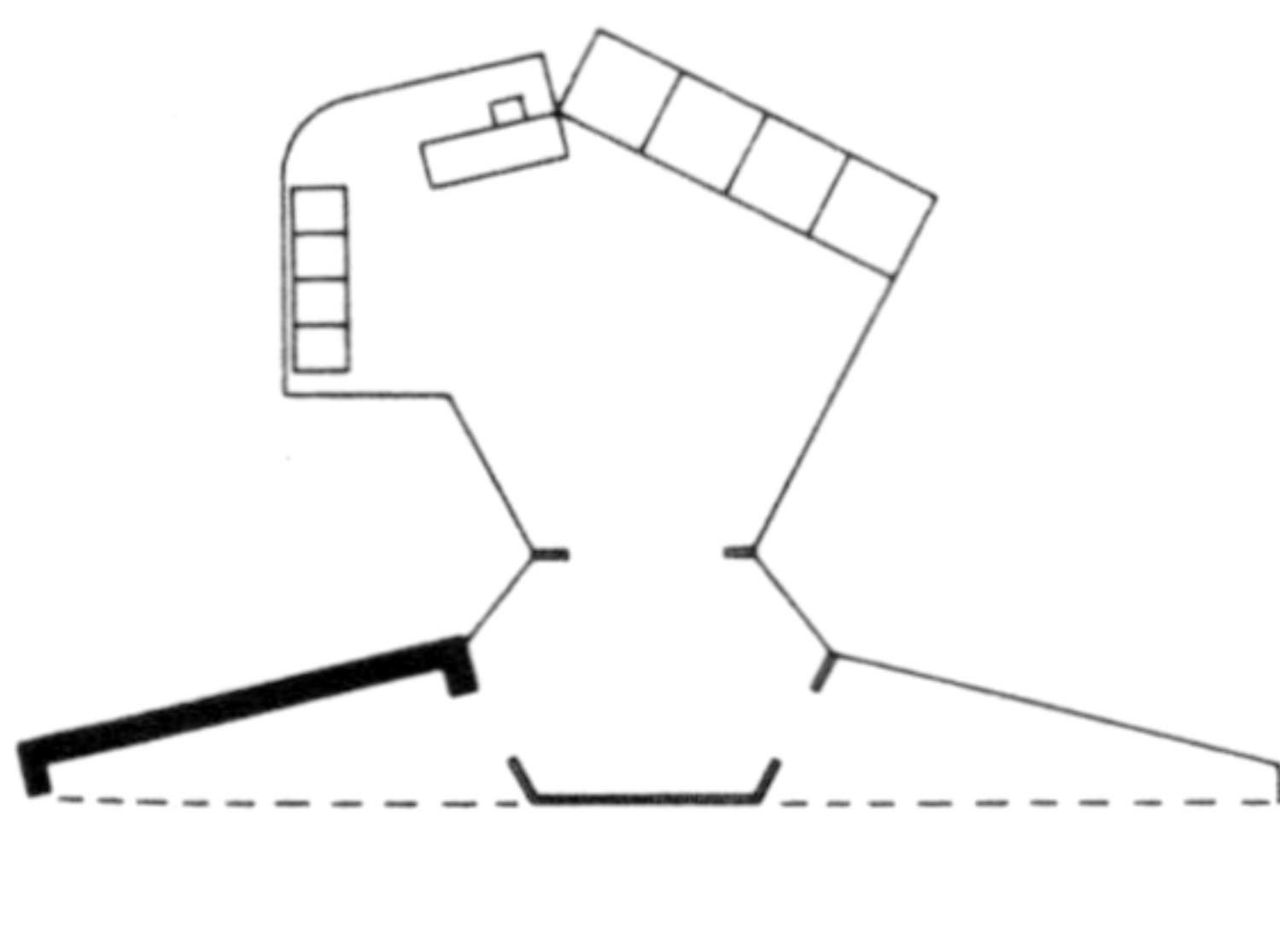

2. Diagram of recessed space relation

Arrangements which cause this conflict are these: If the only cover is in front of the entrance doors or on a direct path in and out of the entrance, and if many people try to shelter, the entrance gets blocked. Even where there is a covered space at the side of the doors, if the doors are set back so that this space runs in at right angles to the pavement from a narrow opening, people will not use it; they will tend to form a line across the opening facing the street, again blocking the entrance.

Arrangements which may prevent the conflict will have some covered space at the side of the entrance doors, so that people can shelter without blocking the doorway. The space must also be recessed to avoid being on any direct path in or out of the entrance. But if it is deeply recessed or not parallel to the street, it is wasted, because people tend to stand in a line facing the street, watching for the rain to lessen. The space must therefore be a shallow linear recess, roughly parallel to the street. A depth of two feet should be sufficient to allow a single line of people to shelter. Note: the length of this space will depend on how busy the pavement is, whether there is a bus stop near by, and how much other shelter is available. A convenient relative length is shown in Figure 2.

Relation 3.

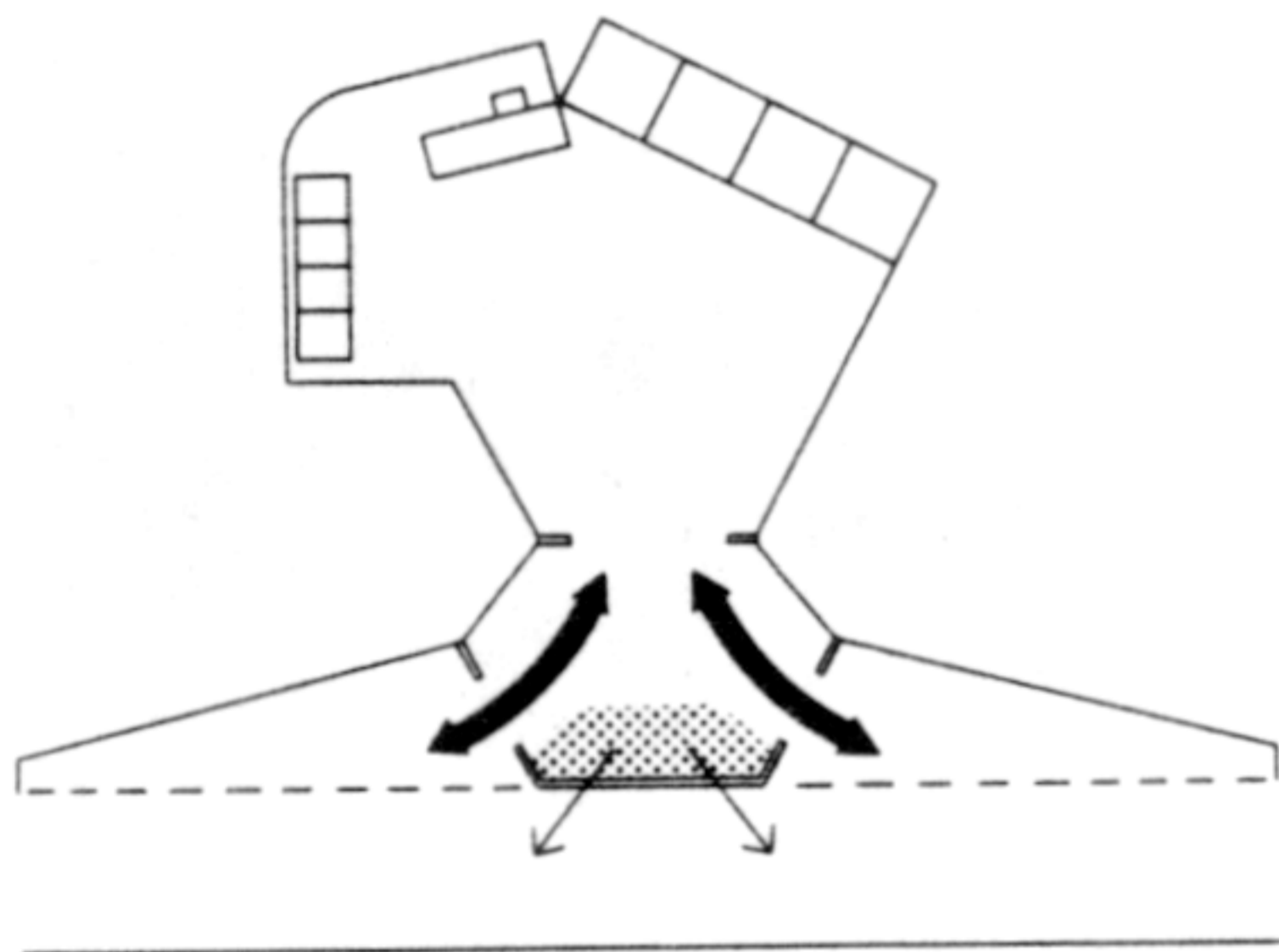

Diagram of the relation for a direct view of the street

Space immediately inside the entrance, close to the doors and clear of all entry and exit paths, with a direct view of the street.

When it is cold and windy, people who are waiting to be picked up by car will want more shelter than the covered entrance provides. The following tendencies conflict:

1. People tend to wait at a point overlooking the street; they will want to know the moment the car they are expecting arrives.
2. People who are waiting try to keep out of the way of those going in and out.

Arrangements which cause this conflict: If the only windows near the entrance doors are in the entrance doors themselves, those who are waiting will tend to crowd around the doors. Even if there is another window near the doors, if the space just inside is close to any path in or out of the entrance, then again people will get in the way. In both these arrangements, people cannot stand by the window and at the same time keep out of the way.

Arrangements which may prevent the conflict: If the entrance lobby is large and surrounded by glass, the conflict will not occur. Indeed any entrance with a space overlooking the street and near the entrance doors will prevent the conflict, provided the space is clear of movement. Figure 3 shows one solution.

Relation 4.

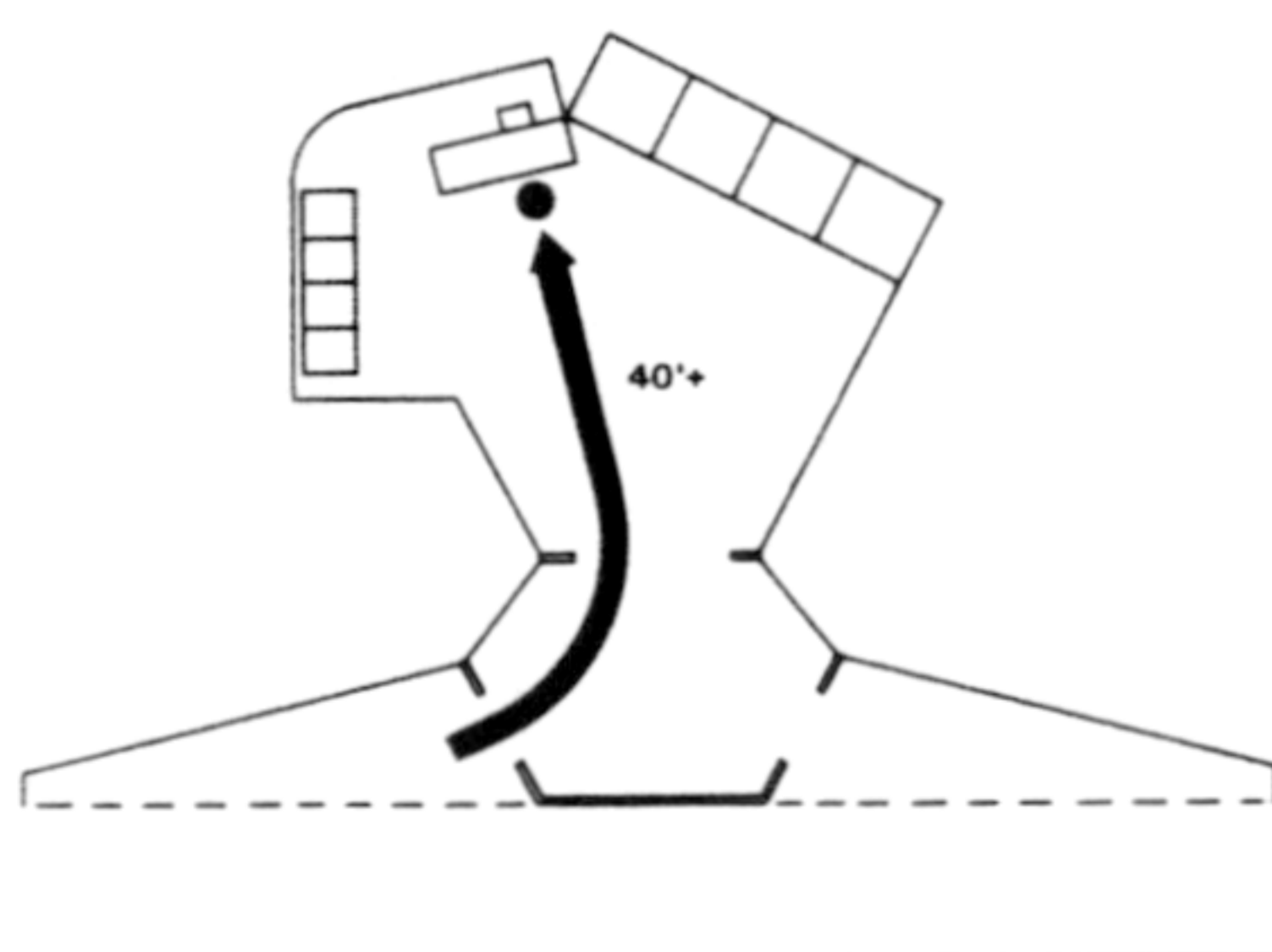

4. Diagram of distance relation

The shortest path from outside the entrance doors to the reception desk is not less than forty feet.

Visitors arrive at the building after finding their way along a busy street. The street is noisy, and they have been jostled along the pavement. The following tendencies conflict:

1. Visitors try to move directly, without hesitation, from the entrance doors to the reception desk.
2. Visitors need a minute or two in which to reorient their thoughts before arriving at the reception desk.

Arrangements which cause this conflict: An entrance which has the receptionist just inside the door, particularly if there is no entryway to protect from drafts.

Arrangements which may prevent the conflict: If the receptionist is placed well away from the entrance doors, or if there are one or more lobbies between the street and reception, the conflict does not occur. The essential property of these arrangements is that the visitor must cross a quiet space

after leaving the street, before arriving at the reception point; forty feet seems to be about the minimum length of such a space. See Figure 4.

Porter made observations of an entrance to a department store in Berkeley.³ A number of display cases separate the store front from the street, forming an arcade between street and store. He found that most people entering the store chose a path through the arcade rather than the direct path between the pavement and door to the store. He suggests, also, that people will choose to use a transition space to reorient themselves, on entering a space which is radically different from the one they have just left.

5. One possible arrangement containing the twenty-two relations for an office entrance

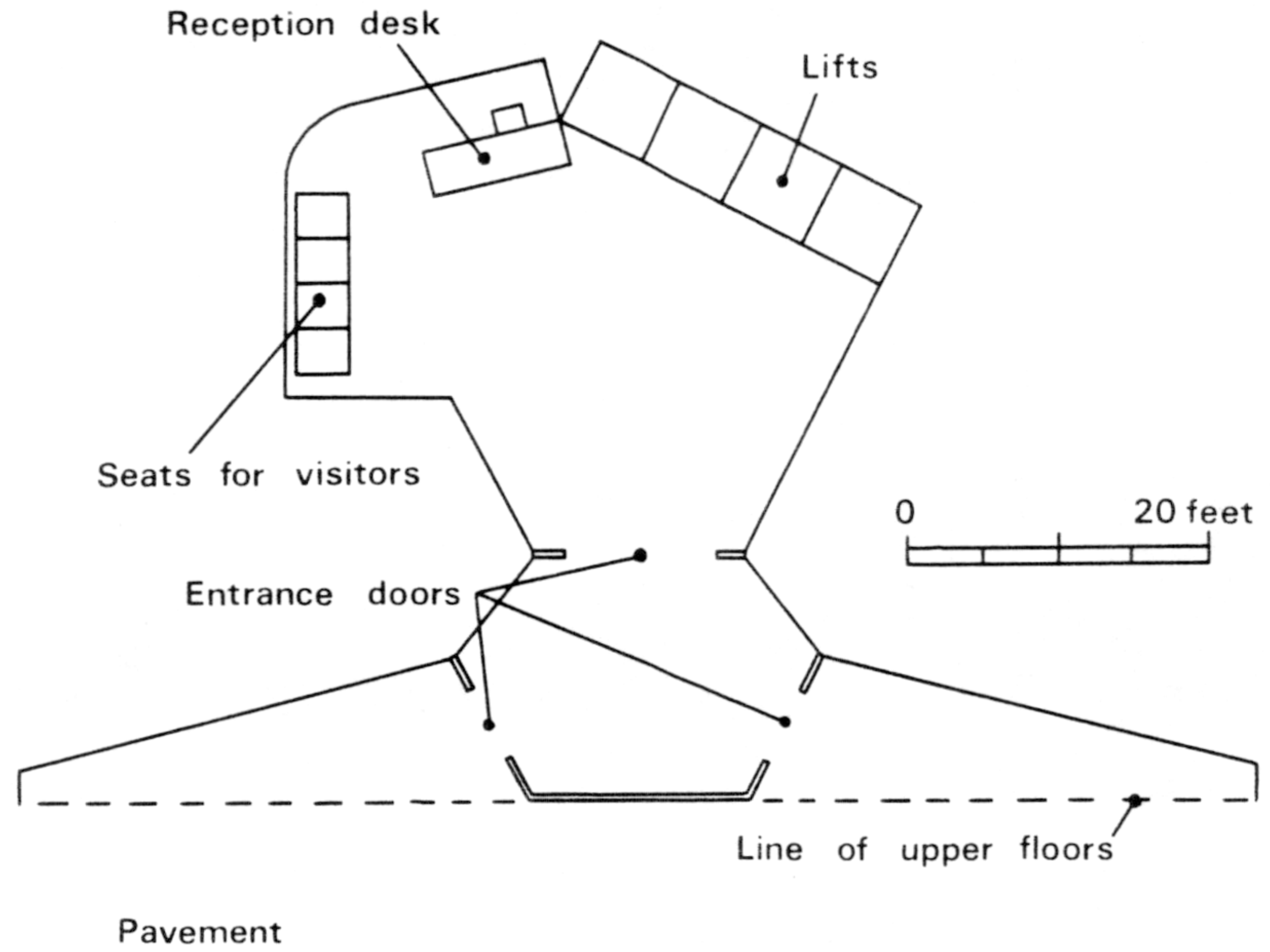

3. *Ibid.*, the study of Hink's Arcade, Berkeley.

Appendix B Patterns for the Entrance to a Suburban House

This appendix⁴ describes four of the twenty-six relations or patterns⁵ that must be present in the entrance to a single-family house standing on its own private lot on a suburban street. Each pattern is a geometric relationship between specified physical elements. Each pattern is necessary, in the sense that a predictable conflict will occur and recur during the life of the house if it is missing.

The twenty-six patterns do not form a perfectly self-contained complex. The circumstances which surround any one particular kind of housing may require only some of these twenty-six or they may require extra ones. The twenty-six patterns must be thought of as a kit of parts to be put together differently in different conditions.

It is therefore important to specify the precise conditions or context under which each individual pattern is necessary. Given knowledge of the circumstances which surround a particular building, it is possible to decide exactly which of the twenty-six it must contain. This detailed specification of conditions will accompany the discussion of each pattern. In general, it can be said that the patterns all apply to the entrance of a single detached suburban house, containing a single family, with or without children; it is assumed that the family owns at least one car and that its way of life is some version of that commonly found in a middle-income suburb in the United States and, more recently, in England. It is assumed that the house stands on a street carrying fairly light traffic, that the house contains a kitchen and some kind of living room, and that these rooms contain windows. These elements are not being questioned. Whether the street should have sidewalks, whether the kitchen should be closed or open, whether there should be one living room or two, whether windows should have built-in curtains, or whether any of these elements should exist at all—none of these questions is being asked.

This does not mean that streets, kitchens, living rooms, windows are right as we now know them. Above all, it does not mean that one-family suburban houses are a good idea. They are very likely not. But discussion of these elements would be fruitless without deep analysis of the relationships which define them. The problem has been deliberately restricted to avoid the dangers of unlimited expansion.

This has an obvious consequence. The twenty-six patterns defined here apply only to certain houses whose other defining patterns are those normal for suburban houses in 1968. As soon as the patterns now defining suburban houses—relatively quiet streets, windows, kitchens, living rooms—are changed, the entrance patterns presented here will have to be reexamined. It is impossible to predict how many of them will be stable under the impact of such changes. However, many will still be required. To this extent the twenty-six patterns form an isolable, independent complex.

Four of the twenty-six patterns are presented. Each has the same format: first a verbal statement of the topic, the context, and the relations which the pattern specifies; second, a description of the problem and conflicting tendencies; third, a description of the kinds of arrangement which cause the conflict and the logic of the solution.

Pattern 1.

Finding house numbers from a moving car.

If: Free-standing house on a street where cars move at speeds between 5 miles per hour and 30 miles per hour.

4. This study was begun by Christopher Alexander in 1966 and revised and extended for this presentation. The original twenty-six patterns for a suburban house are available from the Center for Environmental Structure, Berkeley.

5. The theoretical framework developed in Berkeley from the concept of "relation" to that of "pattern." The distinctions are briefly made here and in Francis Duffy and John Torrey, "A Progress Report on the Pattern Language," in this volume. This appendix is an example of patterns. See also Alexander, Sara Ishikawa, and Murray Silverstein, *A Pattern Language Which Generates Multi-Service Centers*.

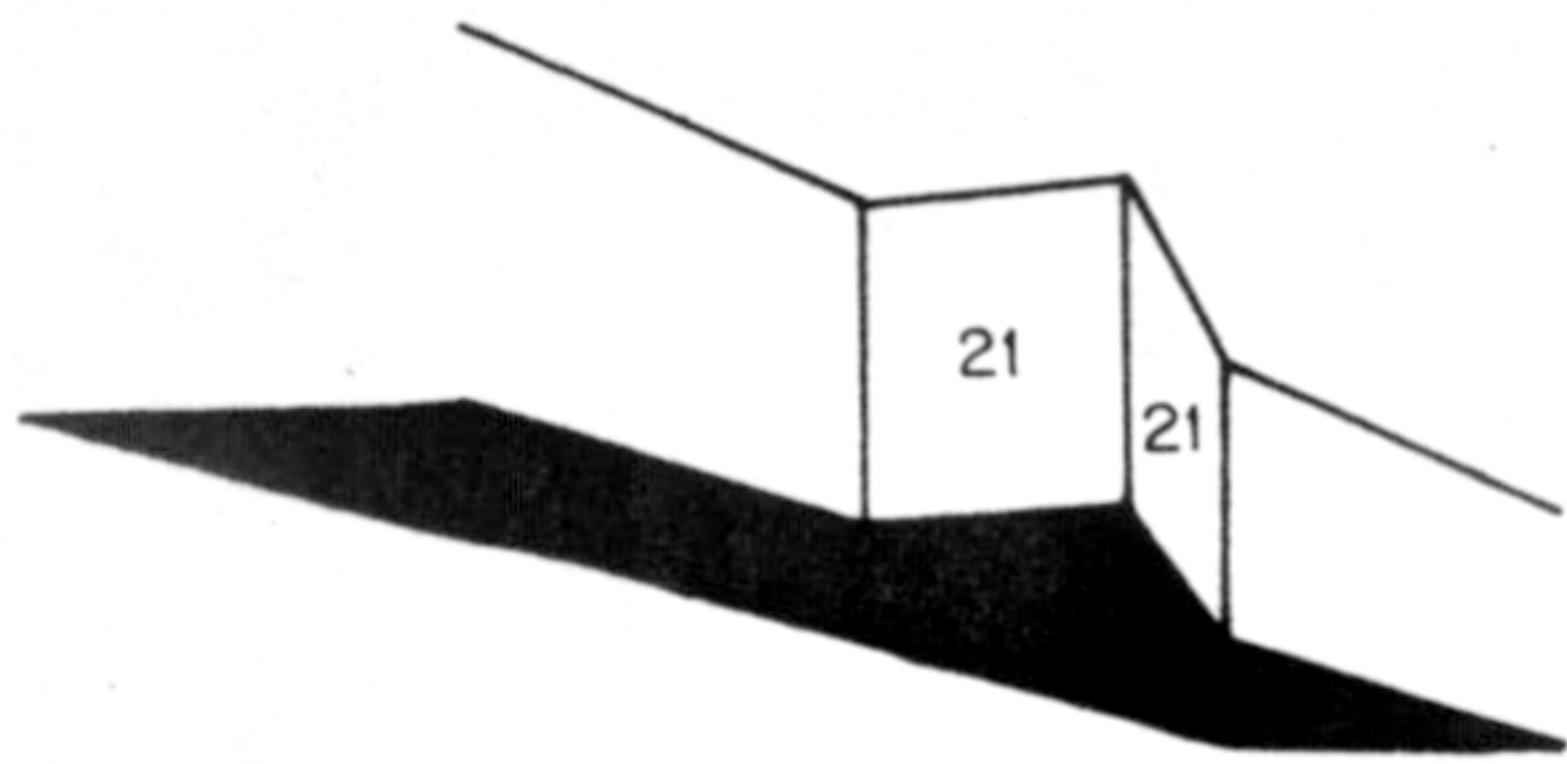

6. Diagram of the pattern of house signs

Then: Two house signs, each at about 45 degrees to the street, facing up and down the street; sign letters 12 inches high, or down to 6 inches if the house is one of a regular sequence of houses all visibly numbered with house signs following this rule. House signs must be 5 feet to 10 feet from the ground and as far forward on the lot as possible.

The problem is that house numbers are hard to see from a moving car, especially for the driver. Many signs have too-small numbers, are parallel to the road (on the house face or garden gate), or they are low enough to be obscured by parked cars or high enough to make the driver crane his neck forward (anything higher than 10 feet may have this effect if the car is near).

The following tendencies conflict:

1. The driver is trying to maintain a reasonable speed on the road, say 25–30 mph.
2. He is trying to identify a house without getting out of his car.
3. He is trying to see the number far enough ahead so that he can slow down and if necessary turn into the driveway.
4. He is trying to keep his eye on the road.

Arrangements that cause this conflict, in addition to numbers that are too small and signs placed too high or too low, include a sign placed at right angles to the street, since this cannot be read from the part of the street in front of the house; a sign more than 10 degrees off the driver's path when close enough to be read;⁶ a sign facing only one way.

This conflict may be resolved as follows: At 30 miles per hour, under average road conditions, the safe stopping distance is 245 feet. Furthermore, it will take about 2 seconds to read the number, or 88 feet at 30 mph.⁷ The sign must therefore be legible 333 feet from the house. For 99 percent of all drivers to be able to read them, the numbers must be 12 inches high to be legible at 333 feet.⁸ Further, so that these numbers are legible from either direction and from the front, they must be placed at an angle to the street, say between 45 and 70 degrees, one facing each direction. The sign must also be as close to the street as possible, so as not to violate the 10 degrees limit. If there is any private land between the sign, and those parts of the street from which the sign is supposed to be visible, trees or outhouses may be put up there in the course of the years and obscure the sign. The sign must therefore be on the property line which divides the street from private property.

At present houses containing this pattern are very rare. However, as soon as the pattern becomes widely accepted, a new factor will come into play: drivers will read house numbers in sequence and slow down as they approach the one they want. Under these conditions it will not be necessary to see the number quite so far ahead, and the numbers may be reduced by half.

Letting people inside the house know who is coming to the door.

If: Entrance to any dwelling.

Then: The area outside the main door at least 200 square feet enclosed by walls on three sides and shielded from the street. Kitchen windows and living room windows open onto this area, but not visible from the street. Parking places within or immediately adjacent to this area, and all parts within this area surfaced in noisy material like gravel or wood.

The problem is that people like to know who is coming before they hear the doorbell. In the United States, where almost everybody has a phone, it has become a common courtesy to call ahead; people like to know who's coming in advance. Knocking on doors before you enter is a widely accepted habit

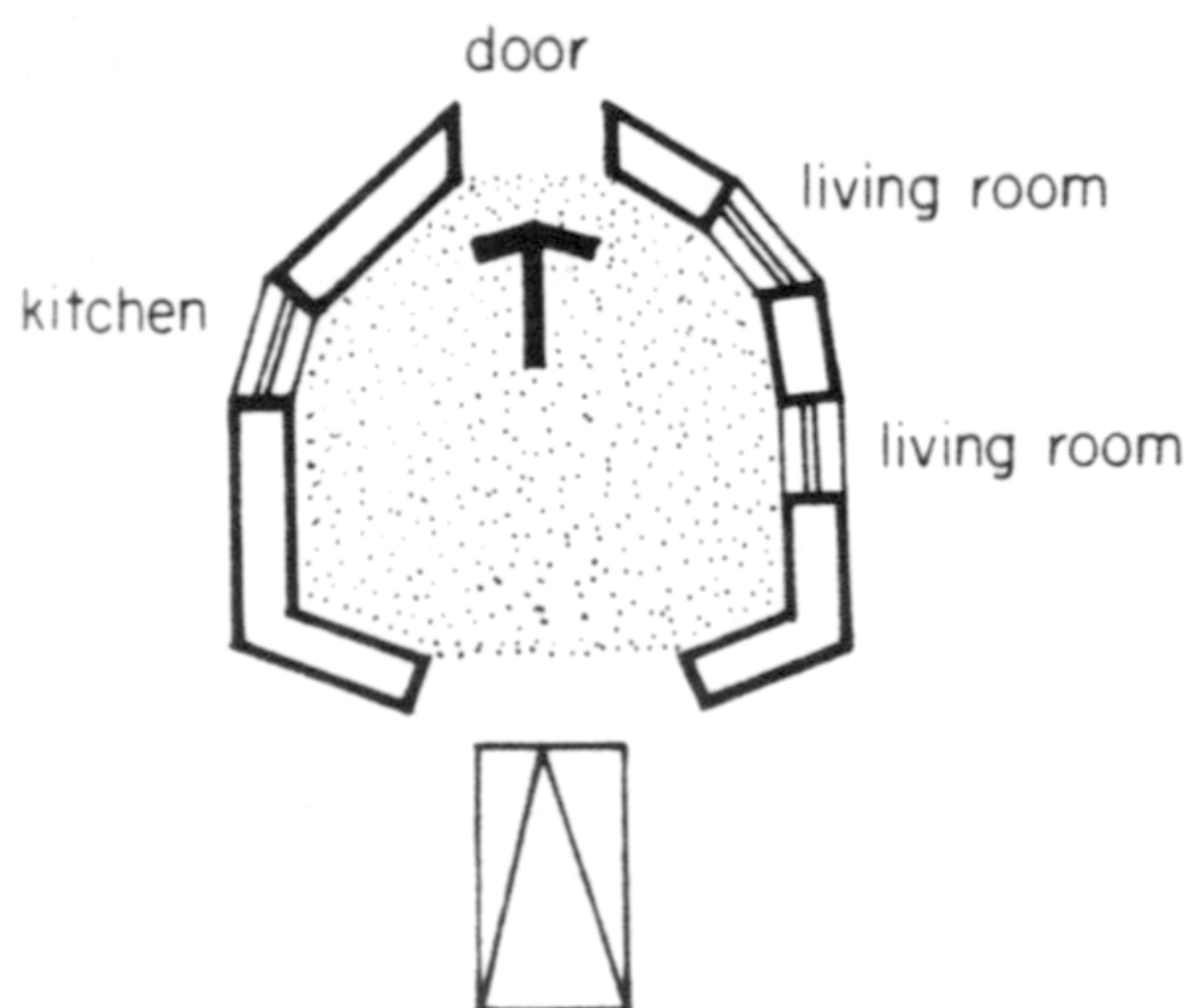

7. Diagram of the pattern of paths leading to the front door

6. R. L. Moore and A. W. Christie, "Research on Traffic Signs."

7. *Ibid.*, especially p. 113 and the formula on p. 117.

8. J. B. Davey, "The Vision of a Group of Drivers."

throughout the Western world. It gives the person inside a chance to adjust himself, mentally, for the coming encounter. In many countries a visitor has to pass through a court before he reaches the house, and while he is in this court he can be seen and heard. However, if the living room or kitchen windows overlook the area in front of the house, they may be exposed directly to the street, which is also undesirable.

The following tendencies conflict:

1. People like to hear visitors coming before the doorbell rings.
2. Visitors tend to take the shortest path off the street, the path to the door is usually within range of street noise, and the noise of arrival is therefore often unnoticed.
3. People tend to "live" away from the street, or if they do live on the street side they tend to keep windows closed.
4. People do not want the inside of the house to be visible from the street.

Some arrangements that cause this conflict are windows that look out on the front but are visible from the street, thus forcing people to curtain them and to live away from them; or a path to the front door that does not pass windows of living areas.

The area in front of the door must be so laid out that the path to the door is visible from windows but the street itself is not. This means that there must be some kind of obstruction placed near the street end of the path. The area must be acoustically shielded from the street; otherwise arrival noises are indistinguishable from street noises. But arrival sounds, like a car engine and footsteps, must be heard, so the car must be brought into the area by the door, and the area must be paved in resonant materials.

Pattern 3.

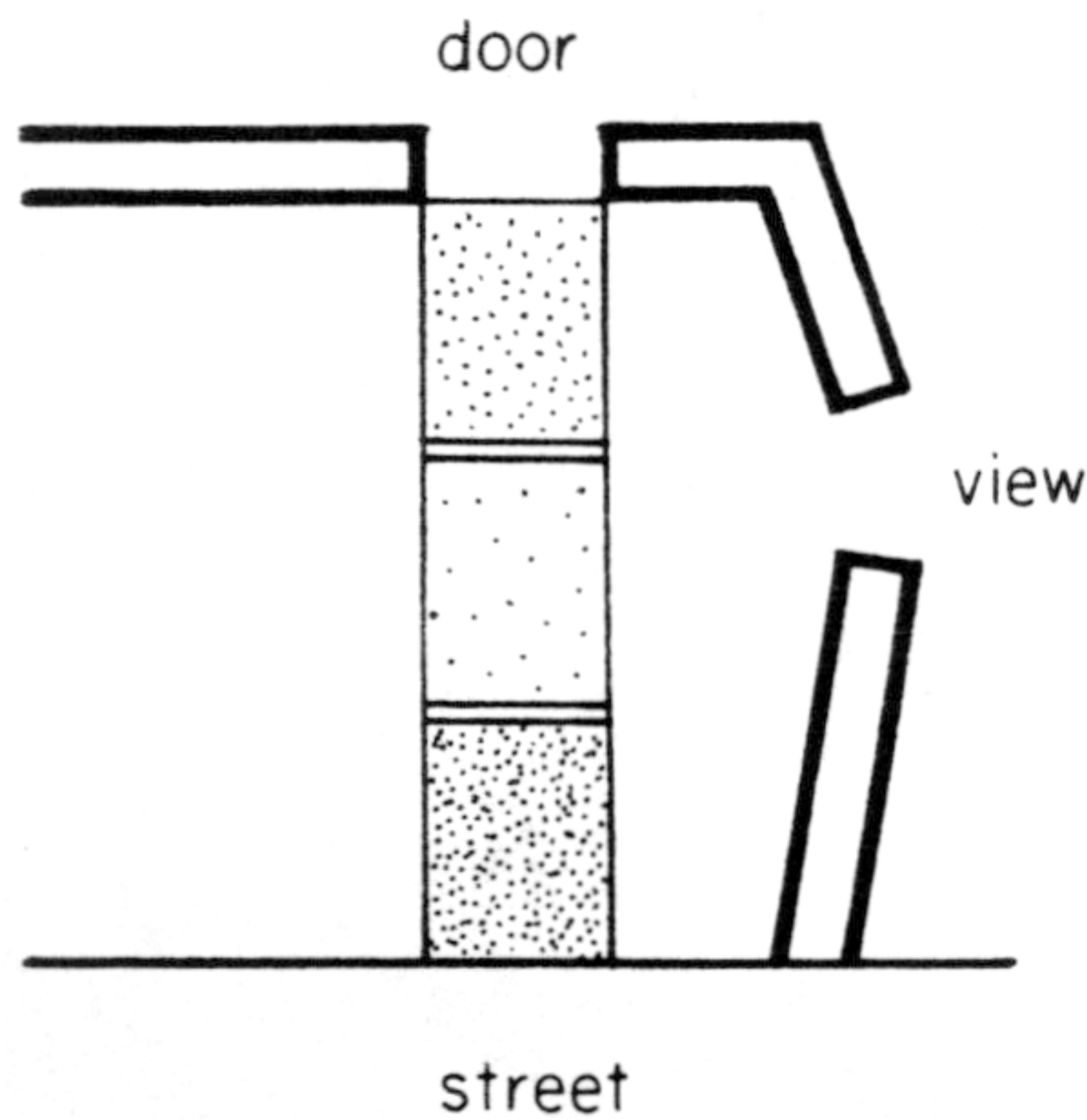

8. Diagram of the change of levels pattern

Transition between street and house in an urban area.

If: Any dwelling in an urban area.

Then: The surface of the paths between street and door and between parking places and door must have at least two changes of level and be made of more than two materials. If possible, there should be some change of view, like an opening into the back garden. The floor of kitchen and living room should be at least one step lower than the floor immediately inside the main door.

The problem is that if the house is too closely associated with the street, people who come into the house find it difficult to lose the "closedness" and tension that are appropriate to street behavior and public encounters, and are thereby prevented from relaxing, or from opening up sufficiently to interact with people in maximum contact.

The following tendencies conflict:

1. On the street people adopt a mask of "street behavior"; the momentum of this mask tends to persist until wiped clean.⁹
2. Arriving home, people search for an inner sanctum where they can relax completely.

Arrangements which cause the conflict are any kind of environmental continuity between street and house, for instance, where the sidewalk continues

9. Evidence for this tendency comes from the report by Serge Bouterline and Robert Weiss, *The Seattle World's Fair*. The authors noticed that many exhibits failed to hold people; they drifted in, then drifted out again within a short time. However, in one exhibit the viewers had to cross a huge, deep-pile, bright orange carpet on the way in. Although the exhibit was not better than other exhibits, they stayed. The authors concluded that people were, in general, under the influence of their own "street and crowd behavior" and that while under this influence they could not relax enough to make contact with the exhibits. But the bright carpet presented them with such a strong contrast that it broke the mood of their outside behavior, in effect "wiped them clean," with the result that they could then become absorbed in the exhibit.

unbroken up to the front door, or where the inside of the house is at the same level as the street or has the same view as from the street.

Arrangements which may prevent the conflict are changes of view, surface materials, and level. A step down into a living room helps destroy the street mask by creating a strong sense of stability and arrival.

Pattern 4.

rooms

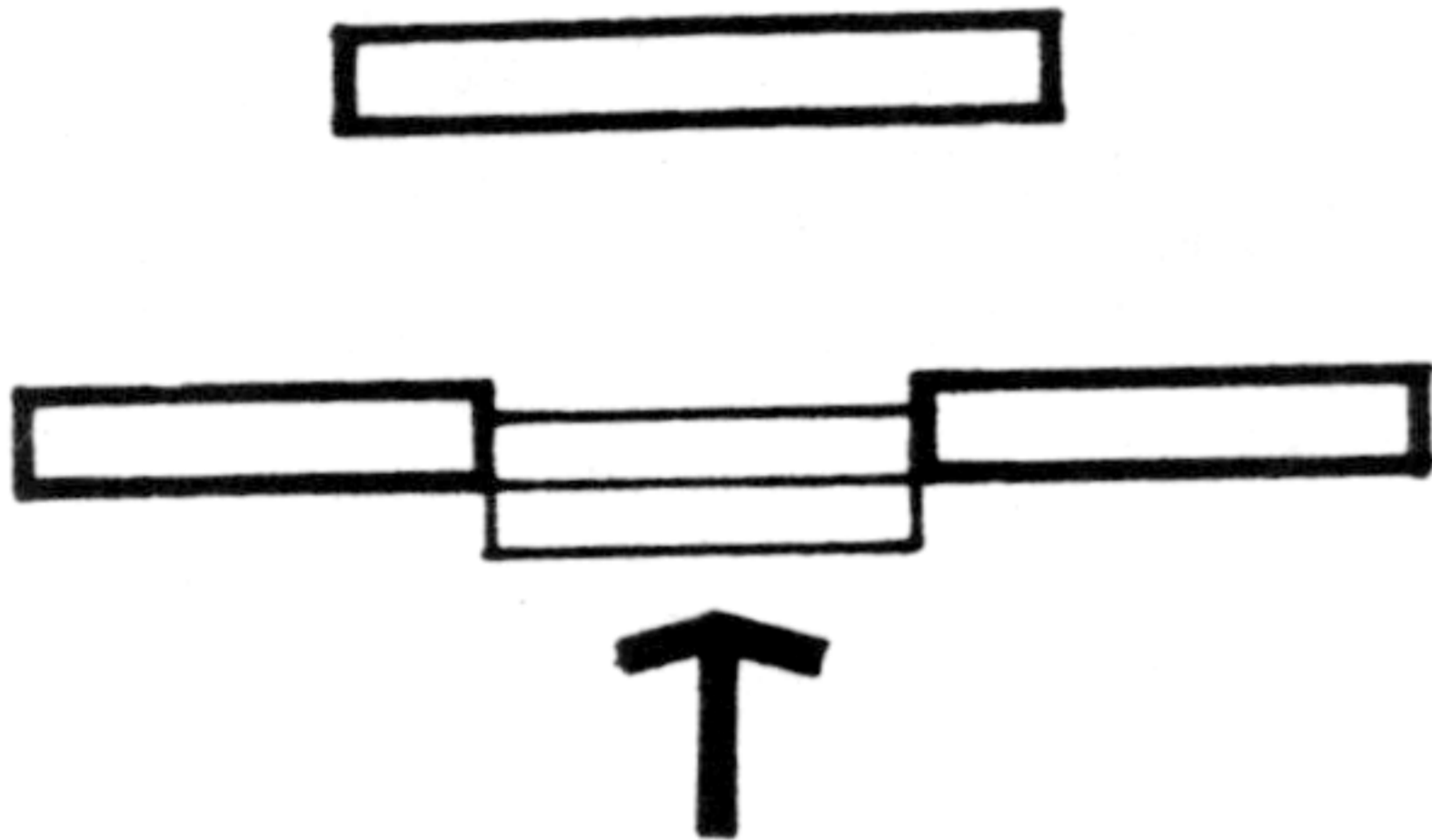

9. Diagram of the doorstep privacy pattern

Privacy when the front door is open.

If: The front door of any dwelling.

Then: Walls inside the main door so placed that a person standing on the doorstep, with the door open, cannot see into any room, especially the living room or kitchen, nor to any passage connecting rooms. The area immediately inside the door must be a dead end. (If there is a window near the front door, the pattern applies also to the areas visible through this window from the doorstep.)

The problem is that people want the inside of the house to be private when they open the front door.

The following tendencies conflict:

1. Politeness demands that when someone comes to the door, the door be opened wide. If the occupant goes back to get something, the door must be left open.
2. People seek privacy for the inside of their houses. In particular, they try to prevent callers from seeing an untidy house.
3. The family, sitting, talking, or at table, do not want to feel disturbed or intruded upon when someone comes to the door.
4. At various times of the day the members of the family may wander around inside the house incompletely dressed.
5. People in the house do not want their movements seen from outside.

Arrangements that cause this conflict are a door that opens directly into any living room, or a door that opens in such a way that a person standing on the step can see into any room whose door is open.

The first part of the pattern is immediate. The argument for the second part is that it may be desirable to have a window opening onto the front doorstep. However, if this window is badly placed it will be curtained and its function destroyed. The window must be placed in such a way that people feel comfortable to leave it uncovered.¹⁰

10. People are reluctant to use clear glass in doors. See Albert Haberer, *Doors and Gates*, pp. 8–12. When clear glass is provided, if the inside rooms or movement are visible, curtains are put over the glass. For a dramatic example consider a recent house by Edward Barnes. Although the living room seems to be screened from the entrance, in fact the glass at the entrance does give onto the sides of the living room, and the path from the bedroom to the kitchen passes right past the glass. Inevitably the architect was forced to put curtains in as soon as the building went into use. See *Architectural Record*, January 1957, p. 208.